

SIGNODE **HBX-4300**TM

Semiautomatic plastic strapping machine

- ***Unmatched simplicity***
Easy to operate and maintain
- ***Jam-resistant technology***
- ***Non-directional strap loading***

Up to
70
straps per
minute!



**Made in
the U.S.A.**

SIGNODE[®]

SIGNODE HBX-4300™

Semiautomatic plastic strapping machine

The new HBX-4300™ semiautomatic strapping machine is the simplest, most reliable general-duty strapping machine on the market today. With 40% fewer parts and more timesaving features, the HBX-4300 machine simplifies operation and maintenance to save you time and money.

Unmatched simplicity

The HBX-4300's simple yet durable design eliminates the use of drive belts and clutches. This combined with other trouble-free maintenance elements like toolless hot knife removal and jam-resistant technology make it easier to operate and more cost effective to maintain than other strapping machines.

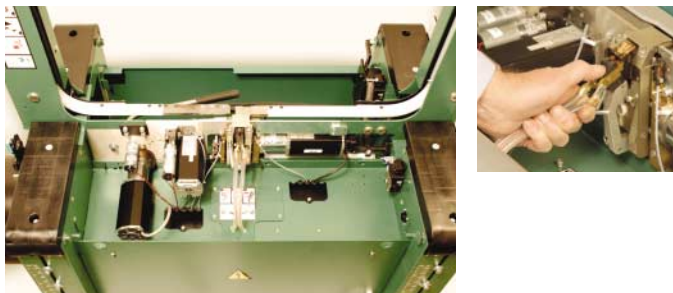

Strap feeds from either direction

Strap coil pays off from either direction, eliminating the downtime and material waste resulting from incorrect coil loading.

Out-of-strap feature

The out-of-strap feature ejects the strap at the end of the coil to eliminate downtime associated with removing the excess strap left in the machine.

Fully accessible strap path

No tools required. Simply raise the tabletop and lift guide for access to strap path.



Automatic cut-off and refeed option

Signode's patented automatic cut-off and refeed feature automatically ejects misfed strap, rethreads itself and continues strapping without operator intervention.

SIGNODE®
180 Hastings Drive
Buffalo Grove, Illinois 60089

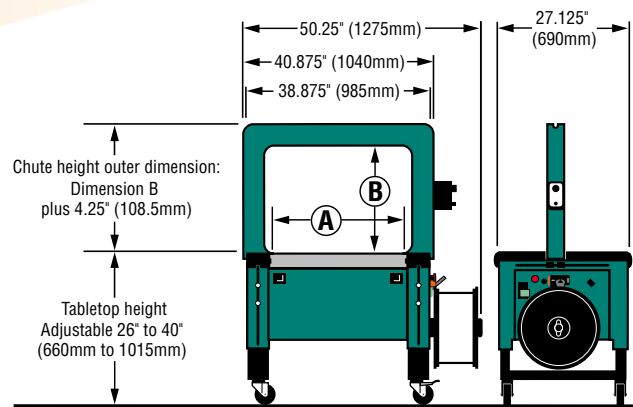

HBX-4300 Chute inner dimensions

	in.	mm	in.	mm	in.	mm	in.	mm	in.	mm
A*	16	405	20	510	28	710	33	840	48	1220
B	10	255	15	380	20	510	30	760	20	510

*Inner dimension A is maximum package size.

HBX-4300 Specifications

Cycle rate: Up to 70 straps per minute. Actual production will vary depending on package size, chute size and operator dexterity.

Maximum package weight: 100 lbs

Strapping: 9mm or 12mm Contrax polypropylene strapping

Electrical requirements: 115 volt, 60Hz; 3 phase voltage optional

Shipping weight: 600 lbs

HBX-4300 Options

- Single or dual compression
Single: Up to 120 lbs at 90 lbs psi
Dual: Up to 240 lbs at 90 lbs psi
- Indicator light alerts operator to low strap/out-of-strap conditions and machine malfunction
- EZ height adjustable leg kit — 26" to 40" (660mm to 1015mm)
- Automatic cut-off and refeed
- Roller top

The HBX-4300 is also available in a stainless steel model as well as an automatic model, the HBX-4330.

Save on strapping costs with HB Series plastic strapping

The new HBX-4300 utilizes Signode's newest Contrax® polypropylene strapping. HB Series strapping has the same durable properties as regular Contrax with more strap per coil.

- HB 612 9mm Contrax coils — 16,000 feet per coil
- HB 812 12mm Contrax coils — 12,000 feet per coil