

SIGNODE **LBX-6520**™

Automatic corrugated bundler

- ***Variable speed reversible conveyors***
- ***“EZ Height” adjustable legs***
- ***Patented automatic cut-off and refeed feature***



**Made in
the U.S.A.**

Up to **50** straps per minute!

SIGNODE LBX-6520™

Automatic corrugated bundler

The new LBX-6520™ corrugated strapping machine is the simplest, most reliable corrugated strapping machine on the market today. With 40% fewer parts and more standard features, the LBX-6520 machine simplifies operation and maintenance to save you time and money.

Strap feeds from either direction

Strap coil pays off from either direction, eliminating the downtime and material waste resulting from incorrect coil loading.



Out-of-strap feature

The out-of-strap feature ejects the strap at the end of the coil to eliminate downtime associated with removing the excess strap left in the machine.

Easy maintenance

The LBX-6520 strapping head has no belts, clutches or pulleys. Hot knife can be removed and cleaned without the use of any tools.



Variable speed reversible conveyor

The LBX-6520's variable speed reversible conveyor integrates with your existing conveyor system, providing for easy set-up and operation. Conveyor direction can be easily reversed by flipping a switch.

Fully accessible strap path

No tools required. Simply raise the tabletop and lift the guide for access to the strap path.



Automatic cut-off and refeed

Signode's patented automatic cut-off and refeed feature automatically ejects misfed strap, rethreads itself and continues strapping without operator intervention.

"EZ Height" adjustable leg kit

The LBX-6520 can be adjusted up to 14 inches for integration into multiple lines. Unlike other adjustable leg kits, it requires only an Allen and socket wrench for adjusting. No forklift required.

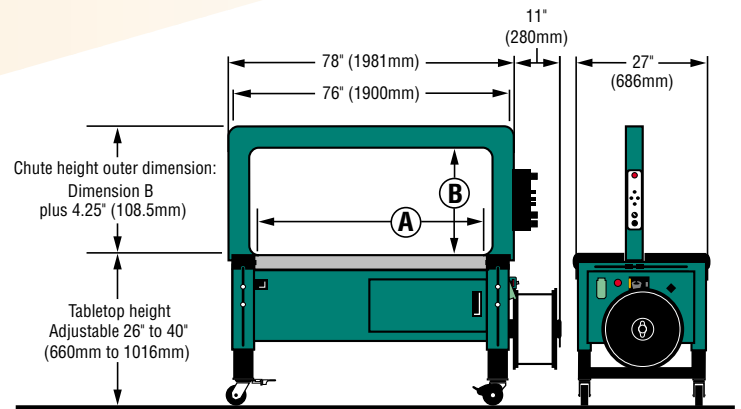

Chute inner dimensions:

	inches	mm
A	65	1650
B	20	510

LBX-6520 Specifications

Cycle rate: Up to 50 straps per minute. Actual production will vary depending on package size, chute size and operator dexterity.

Maximum package weight: 100 lbs on machine or conveyor

Strapping: LB112 5mm Contrax polypropylene strapping

Strap tension: Adjustable from 2 lbs to 60 lbs

Electrical requirements:

208 volt, 60Hz; 230 volt, 60Hz; 460 volt, 60Hz; 575 volt, 60Hz

Shipping weight: 1100 lbs

LBX-6520 Options

- Floor lock kit
- Footswitch
- Palm button
- Indicator light alerts operator to low strap/out-of-strap conditions and machine malfunction
- Conveyor interlock kit
- Extra tall height kit — 41" to 55" (1041 to 1397mm)

Save up to 20% on material costs with LB Series plastic strapping

The new LBX-6520 utilizes Signode's Contrax® polypropylene strapping. LB Series strapping has the same durable properties as regular Contrax with more strap per coil.

- LB 112 5mm Contrax coils — 30,000 feet per coil

SIGNODE®

180 Hastings Drive
Buffalo Grove, Illinois 60089